

THE INFORMATION CONTAINED IN THIS DRAWING IS THE SOLE PROPERTY OF VTE INCORPORATED. ANY REPRODUCTION IN PART OR WHOLE WITHOUT THE WRITTEN PERMISSION OF VTE INCORPORATED IS PROHIBITED. VTE MAKES NO WARRANTY, EXPRESSED OR IMPLIED, AS TO THE SUITABILITY OF A PRODUCT FOR ANY INTENDED USE. THE CUSTOMER SHALL BEAR THE SOLE RESPONSIBILITY OF DETERMINING THE SUITABILITY OF ANY VTE PRODUCT FOR ITS END USE.

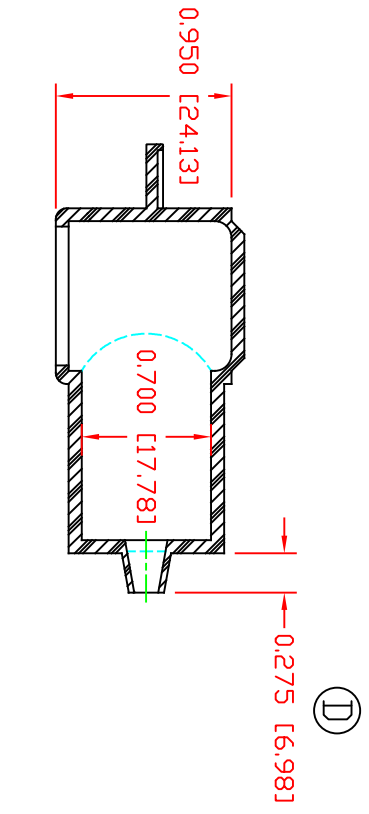

SECTION A-A
 TYP. WALL THICKNESS = .070" [1.8]
 SEAL NO. 1 SHOWN

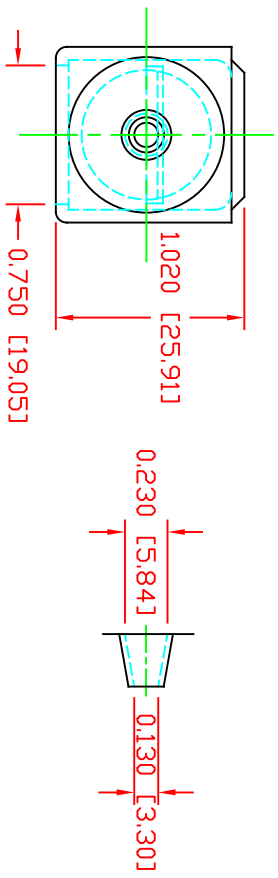

SEAL THICKNESS = .030" [.8]
 ND. 1
 Wire Gages
 18 - 10

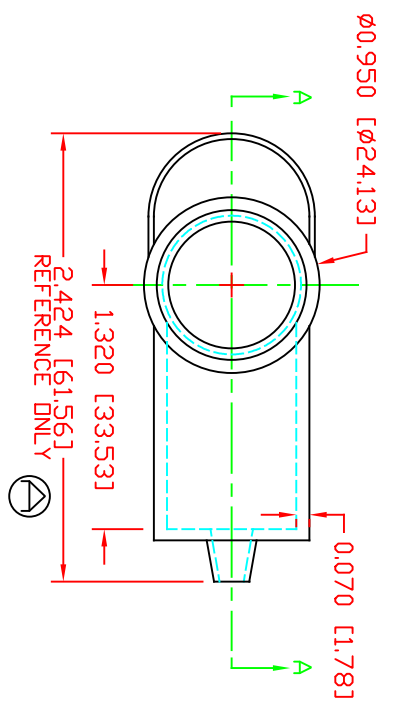

MATERIAL PART NO: 1101650102
 MATERIAL: PVC
 VENDOR PART NO: 9812-65-RED 683
 SHORE DUREMETER: "A" 10 SEC. 65
 SPECIFIC GRAVITY: 1.34
 ULT. ELONGATION %: 400
 MELTING TEMP: 315-335 F [157-168 C]
 BRITTLE TEMP: -54 F [-48 C]
 Tensile Strength PSI: 1550 PSI
 Dielectric Strength, v./mil: 511
 U.L. Rating: V2

LR	REVISIONS	DATE	INT.
A	ADDED REFERENCE DIMENSION	02-25-16	RAS
B	UPDATED BLUE MATERIAL INFORMATION	08-01-22	RAS
C	UPDATED CLEAR MATERIAL INFORMATION	10-24-23	RAS
D	0.275 [6.98] WAS 0.214 [5.42]	10-23-24	RAS

SCALE FACTOR : NONE
 ALL DIMENSIONS GIVEN AS [in, (mm)]
 TOLERANCES UNLESS OTHERWISE SPECIFIED :
 MOLDED PARTS: ±.030" (±0.8mm)
 ALL ANGLES ARE ± 1 DEGREE



VTE Incorporated
 5437 Robinson Road, P.O. Box 790
 Pellston, Michigan 49769
 Telephone: 1-800-527-9256, 231-539-8000
 FAX: 231-539-0914

REF.	DATE:	DRN BY:	JC	WEIGHT:
CUSTOMER DIMS	03-20-98	CHK'D BY:	JC	.019 LBS [8.75 g]
TITLE: TERMINAL INSULATOR CAP				
MATERIAL: PVC		PART NO: 220N1V02		
COLOR: RED		DRG CLASS: REV D		

DD NOT SCALE