

PANEL CUT-OUT

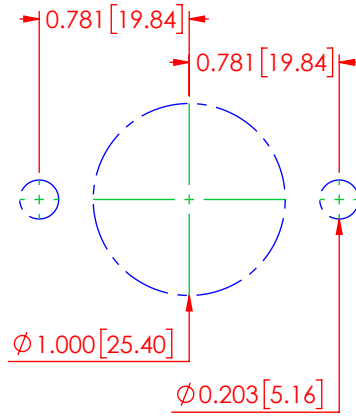

REVISIONS			
REV.	DESCRIPTION	DATE	APPROVED
A	Updated Fastener Torque Values	1-24-23	RAS

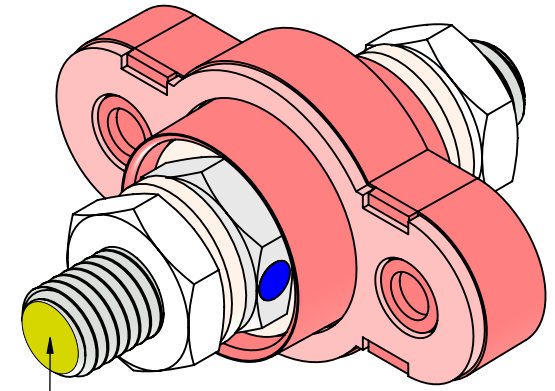

Yellow Dot to Identify Metric Thread

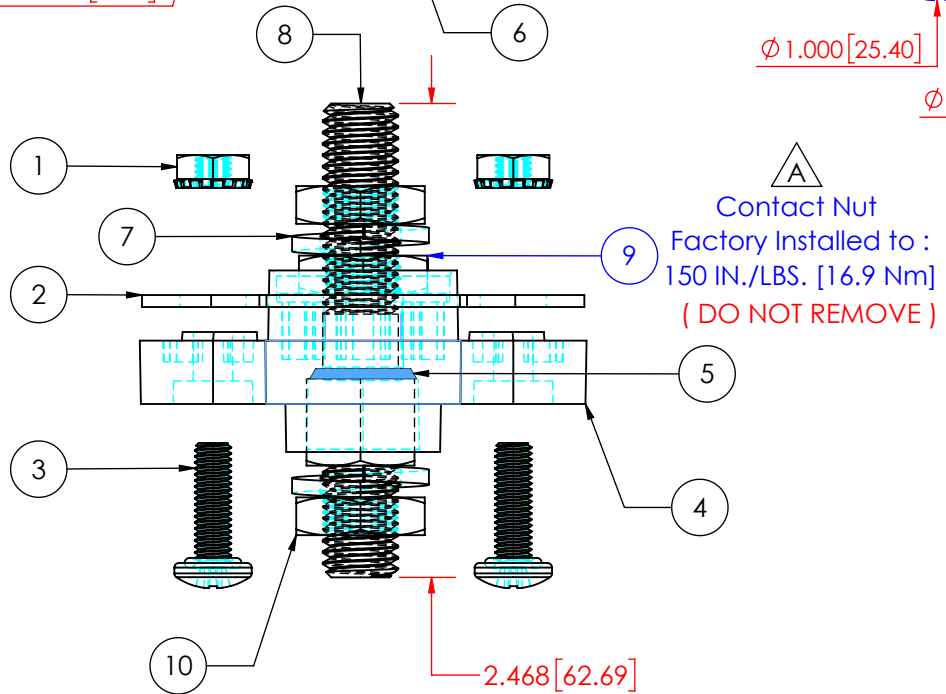

BULK PACKED SEPARATELY			
ITEM NO.	PART NUMBER	DESCRIPTION	QTY.
1	3841-003	10-32 18-8 Stainless Steel Lock Nut	2
2	3960-004	Norseal Red Silicone Gasket	1
3	3737-003	10-32 18-8 Stainless Steel Panhead Sealing Screw .625"	2

ITEM NO.	PART NUMBER	DESCRIPTION	QTY.
4	326D2N02	Glass Filled Nylon Housing (Red)	1
5	3961-001	3/8" / 10mm Buna-N O-Ring	1
6	3646-000	3/8" 18-8 Stainless Steel Flat Washer	1
7	3638-M	M10 18-8 Stainless Steel Lock Washer	2
8	3739-008	M10 x 1.5 Nickel Plated Brass Double Ended Stud	1
9	3845-B04	10mm x 1.5 Tin Plated Brass Heavy Hex Nut	1
10	3845-000	10mm x 1.5 316 Stainless Steel Heavy Hex Jam Nut	2

MAXIMUM VOLTAGE : 0 - 48 VDC
 MAXIMUM AMPERAGE : 250 AMPS @ 12 VDC

MATERIAL PART NO: 7111210502
 MATERIAL: GLASS FILLED NYLON
 HYLON N2015 NAT

MAX 10mm FASTENER TORQUE: 127 IN./LBS. [14.3 Nm]
 MAX 10-32 FASTENER TORQUE: 31.7 IN./LBS. [3.58 Nm]

Assembly Weight : 0.415 Lbs.[197 g]
 Assembly Color : Red
 ALL DIMENSIONS GIVEN AS : INCH [METRIC]
 TOLERANCES UNLESS OTHERWISE SPECIFIED :
 MOLDED PRODUCTS : ±.030" / ±0.8mm
 HARDWARE PRODUCTS : ±.010" / ±0.25mm

PRINTED COPIES ARE NOT CONTROLLED
PROPRIETARY AND CONFIDENTIAL
 THE INFORMATION CONTAINED IN THIS DRAWING IS THE SOLE PROPERTY OF VTE INCORPORATED. ANY REPRODUCTION IN PART OR AS A WHOLE WITHOUT THE WRITTEN PERMISSION OF VTE INCORPORATED PROHIBITED.



VTE INCORPORATED

5437 Robinson Road, P.O. Box 790
 Pellston, Michigan 49769 USA
 Telephone : 1-800-527-9256, 231-539-8000
 Fax : 231-539-0914, Efax : 231-344-5914

REV	A	NAME	DATE
SIZE	A	DRAWN BY:	RAS 1-24-23
		CHECKED BY:	PJK 1-24-23
DO NOT SCALE DRAWING			

TITLE:	M10 Water Proof Pass Through
DWG. NO.	77210W02