

PROPRIETARY RIGHTS ARE CLAIMED FOR THE MATERIAL DISCLOSED IN THIS DRAWING.

LTR.	REVISIONS	DATE	INT.
A	MATERIAL REVISED TO AGREE WITH PARTS AS MFG'D.	07-20-09	JC
B	UPDATED MATERIAL INFORMATION	8-02-22	RAS

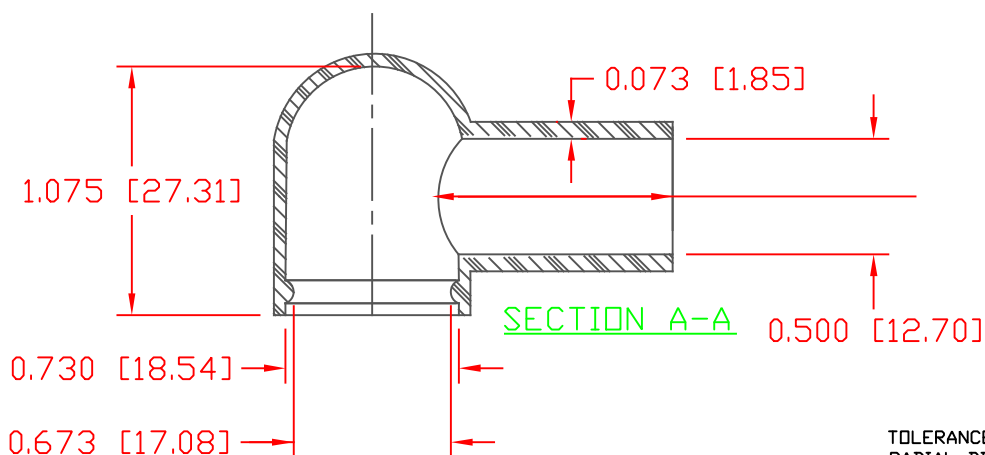
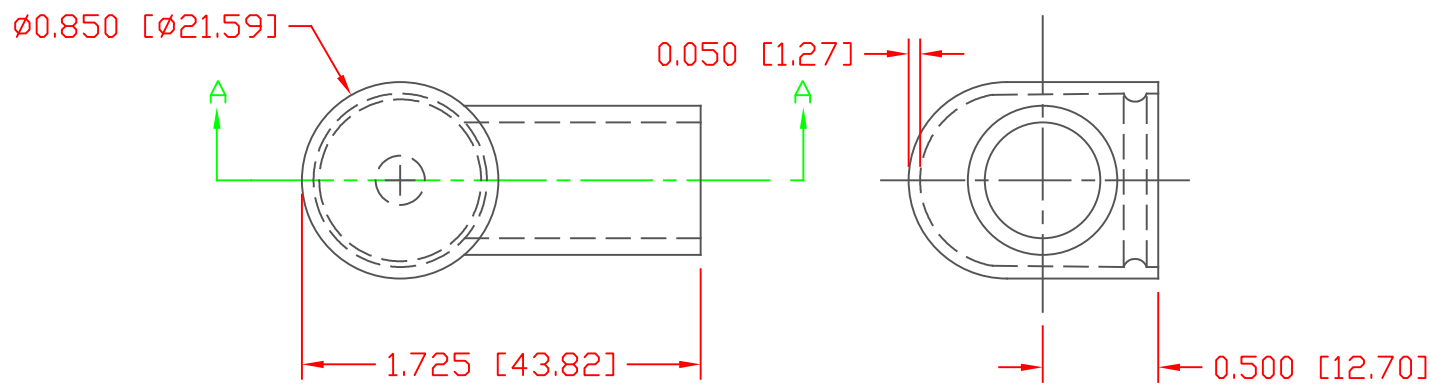

UP TO THREE DEGREES  
DRAFT PERMISSIBLE  
THIS DISTANCE ONLY

TOLERANCE UNLESS OTHERWISE SPECIFIED:  $\pm 0.030$ "/ $\pm 0.8$ mm  
RADIAL DIAMETERS TO BE MEASURED OVER MANDRELS,  
RING GAGES OR PIN GAGES OF SUITABLE SIZE



MATERIAL PART NO:	1101650114
MATERIAL:	PVC
VENDOR PART NO:	9812-65-BLACK
SHORE DUROMETER:	"A" 10 SEC. 65
SPECIFIC GRAVITY:	1.34
ULT. ELONGATION %:	400
MELTING TEMP:	315-335 F [157-168 C]
BRITTLE TEMP:	-54 F [-48 C]
Tensile Strength PSI:	1550 PSI
Dielectric Strength, v./mil	453
U.L. Rating:	V2

		<b>VTE Incorporated</b> 5437 Robinson Road, P.O. Box 790 Pellston, Michigan 49769 Telephone: 1-800-527-9256, 231-539-8000 FAX: 231-539-0914	
		REF:	DATE: 9-30-03
TITLE: EYELET TERMINAL BOOT			
MATERIAL: PVC		PART NO.	
COLOR: BLACK	DRG CLASS: REV B	800N9V14	